

DESIGN NOTES

Rail-to-Rail I/O and 2.4V Operation Allow UltraFast Comparators to be Used on Low Voltage Supplies – Design Note 248

Glen Brisebois

The new LT[®]1711 to LT1714 family of UltraFast[™] comparators have full differential rail-to-rail inputs and outputs and operate down to 2.4V, allowing unfettered application on low supply voltages. The LT1711 (single) and LT1712 (dual) are specified at 4.5ns of propagation delay and 100MHz toggle frequency. The lower power LT1713 (single) and LT1714 (dual) are specified at 7ns of propagation delay and 65MHz toggle frequency. All of these comparators are fully equipped to support multiple supply applications and have Latch Enable (LE) pins and complementary outputs like the popular LT1016, LT1116, LT1671 and LT1394. They are available in MSOP and SSOP packages, fully specified over commercial and industrial temperature ranges on 2.7V, 5V and ±5V supplies.

Simultaneous Full Duplex 75Mbaud Interface with Only Two Wires

The circuit of Figure 1 shows a simple, fully bidirectional, differential 2-wire interface that gives good results to 75Mbaud, using the lower power LT1714. Eye diagrams under conditions of unidirectional and bidirectional communication are shown in Figures 2 and 3. Although not as pristine as the unidirectional performance of Figure 2, the performance under simultaneous bidirectional operation is still excellent. Because the LT1714 input voltage range extends 100mV beyond both supply rails, the circuit works with a full ±3V (one whole V_S up or down) of ground potential difference.

The circuit works well with the resistor values shown, but other sets of values can be used. The starting point is the characteristic impedance, Z_0 , of the twisted-pair cable. The input impedance of the resistive network should match the characteristic impedance and is given by:

$$R_{IN} = 2 \cdot R_0 \cdot \frac{R1 || (R2 + R3)}{R_0 + 2 \cdot [R1 || (R2 + R3)]}$$

This comes out to 120Ω for the values shown. The Thevenin equivalent source voltage is given by:

$$V_{TH} = V_S \cdot \frac{(R2 + R3 - R1)}{(R2 + R3 + R1)} \cdot \frac{R_0}{R_0 + 2 \cdot [R1 || (R2 + R3)]}$$

This amounts to an attenuation factor of 0.0978 with the values shown. (The actual voltage on the lines will be cut in half again due to the 120Ω Z_0 .) The reason this attenuation factor is important is that it is the key to deciding the ratio between the R2-R3 resistor divider in the receiver path. This divider allows the receiver to reject the large signal of the local transmitter and instead sense the attenuated signal of the remote transmitter. Note that in the above equations, R2 and R3 are not yet fully

LT, LTC and LT are registered trademarks of Linear Technology Corporation. UltraFast is a trademark of Linear Technology Corporation.

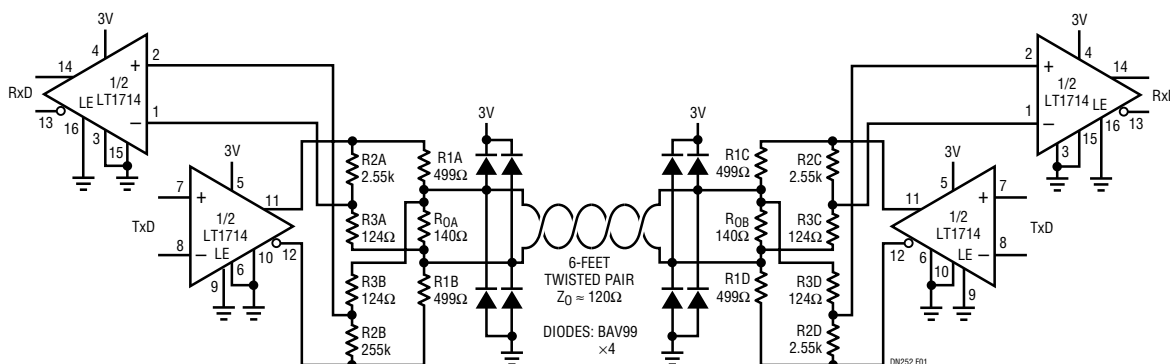

Figure 1. 75Mbaud Full Duplex Interface on Two Wires

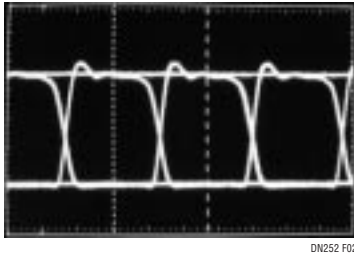

Figure 2. Performance of Figure 1's Circuit When Operated Unidirectionally. Eye is Wide Open

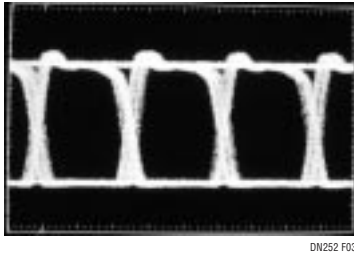

Figure 3. Performance When Operated Simultaneous Bidirectionally (Full Duplex). Crosstalk Appears as Noise. Eye is Slightly Shut But Performance is Still Excellent.

determined because they only appear as a sum. This allows the designer to now place an additional constraint on their values. The R2-R3 divide ratio should be set to equal half the attenuation factor mentioned above or:

$$R3/R2 = 1/2 \cdot 0.0976^1.$$

Having already designed R2 + R3 to be 2.653k (by allocating input impedance across R₀, R1 and R2 + R3 to get the requisite 120Ω), R2 and R3 then become 2529Ω and 123.5Ω respectively. The nearest 1% value for R2 is 2.55k and that for R3 is 124Ω.

1MHz Series Resonant Crystal Oscillator with Square and Sinusoid Outputs

Figure 4 shows a classic 1MHz series resonant crystal oscillator. At series resonance, the crystal is a low impedance and the positive feedback connection is what brings about oscillation at the series resonant frequency. The RC feedback around the other path ensures that the circuit does not find a stable DC operating point and refuse to oscillate. The comparator output is a 1MHz square wave (top trace of Figure 5) with jitter measured at 28ps_{RMS} on a 5V supply and 40ps_{RMS} on a 3V supply. At Pin 2 of the comparator, on the other side of the crystal, is a clean sine wave except for the presence of the small high frequency

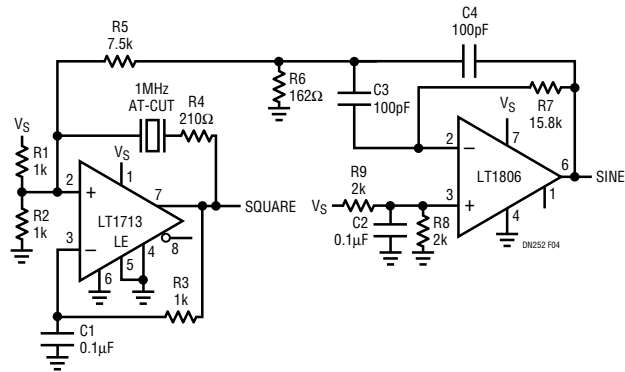

Figure 4. LT1713 Comparator is Configured as a Series Resonant Xtal Oscillator. LT1806 Op Amp is Configured in a Q = 5 Bandpass with f_c = 1MHz

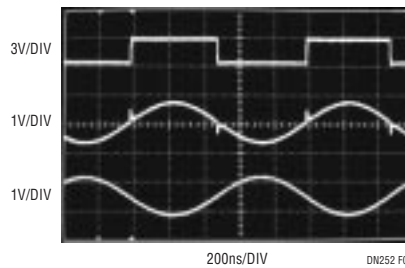

Figure 5. Oscillator Waveforms with V_S = 3V. Top is Comparator Output. Middle is Xtal Feedback to Pin 2 at LT1713 (Note the Glitches). Bottom is Buffered, Inverted and Bandpass Filtered with a Q = 5 by LT1806

glitch (middle trace of Figure 5). This glitch is caused by the fast edge of the comparator output feeding back through crystal capacitance. Amplitude stability of the sine wave is maintained by the fact that the sine wave is basically a filtered version of the square wave. Hence, the usual amplitude control loops associated with sinusoidal oscillators are not necessary.² The sine wave is filtered and buffered by the fast, low noise LT1806 op amp. To remove the glitch, the LT1806 is configured as a bandpass filter with a Q of 5 and unity-gain center frequency of 1MHz, with its output shown as the bottom trace of Figure 5. Distortion was measured at -70dBc and -55dBc on the second and third harmonics, respectively.

¹ Using the design value of R2 + R3 = 2.653k rather than the implementation value of 2.55k + 124Ω = 2.674k.

² Amplitude will be a linear function of comparator output swing, which is supply dependent and therefore adjustable. The important difference here is that any added amplitude stabilization or control loop will not be faced with the classical task of avoiding regions of nonoscillation versus clipping.

Data Sheet Download

<http://www.linear-tech.com/go/dnLT1711> and <http://www.linear-tech.com/go/dnLT1712>
<http://www.linear-tech.com/go/dnLT1713> and <http://www.linear-tech.com/go/dnLT1714>

For literature on our UltraFast Comparators, call 1-800-4-LINEAR. For applications help, call (408) 432-1900, Ext. 2156